

ABIDE BY ROHS,MEETS PT ENVIRONMENTAL Q3-7584

REV.	DESCRIPTION	ECN NO.	NEW DESIGNER
A	NEW RELEASE		杨波 2015.07.08
B	修改对插大小窗口改善接触不稳定现象		杨波 2015.12.09

NOTES:

- MATERIALS:  
SHELL:BRASS;  
MATERIAL:THERMOPLASTIC. UL94-V0;  
CONTACT:PHOSPHOR BRONZE;
- PLATING:  
CONTACT:NICKEL UNDERPLATING OVERALL;  
PLATED GOLD ON CONTACT AREA,  
OR REFERENCE PART NO. CODE;  
PLATED TIN ON SOLDER AREA;  
SHELL: NICKEL PLATING OVERALL;
- DIMENSIONAL TOLERANCE:  
NOT SPECIFIED TOLERANCE,COMPLIED TO THE GENERAL TOLERANCE;  
CONTROL DIMENSIONS INDICATED FORM "▽",MUST BE INSPECTED BY QC;
- ELECTRICAL CHARACTER:  
LOW LEVEL CONTACT RESISTANCE:30mΩ Max.;  
INSULATION RESISTANCE:100MΩ Min.;  
DIELECTRIC WITHSTANDING VOLTAGE:500 VAC;  
CURRENT RATING:0.5A;  
VOLTAGE RATING:40 AC (rms)
- MECHANICAL CHARACTER:  
INSERTION FORCE:44.1NMax.;  
EXTRACTION FORCE:19.6NMin.;  
DURABILITY:5000 CYCLES;

PART NO. CODE:

B-HDM-3-R\*\*\*\*02\*

- ① SERIES:  
HDM-3:HDMI CONNECTOR, SERISES A PLUG,  
SOLDER TYPE
- ② POSITIONS:  
R: 27 POSITIONS.
- ③ COLOR OF HOUSING:  
K:BLACK  
W:WHITE  
C:CREAM-COLOR
- ④ CONTACT PLATED:  
1:PLATED Au 1u" MIN  
2:PLATED Au 3u" MIN  
3:PLATED Au 10u" MIN  
4:PLATED Au 15u" MIN  
5:PLATED Au 30u" MIN
- ⑤ SHELL PLATING:  
1:PLATING Sn  
2:PLATING NICKEL  
3:PLATING Au
- ⑥ MATERIAL OF HOUSING:  
1:PBT  
3:LCP  
9:PA-9T
- ⑦ ENVIRONMENT:  
0:RoHS  
N:HALOGEN FREE

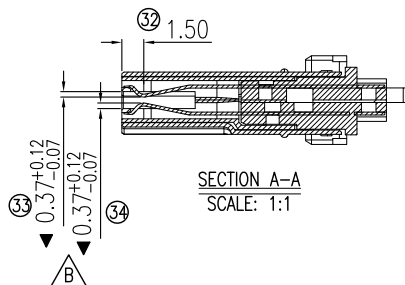
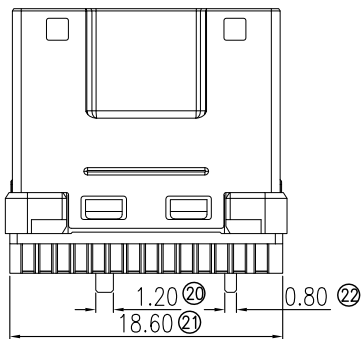
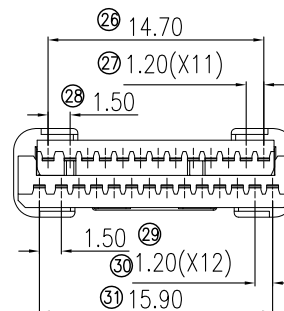
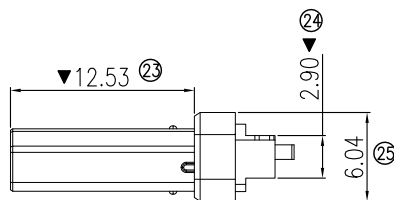
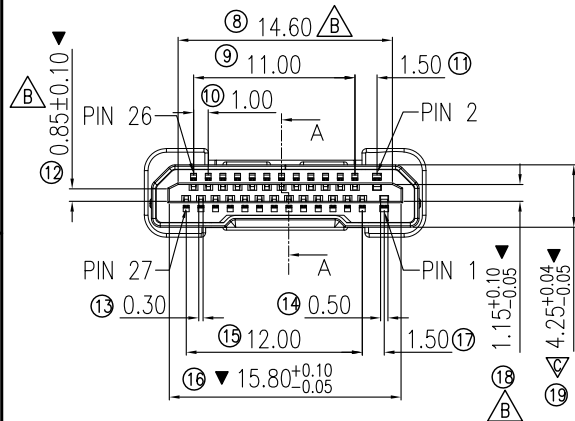
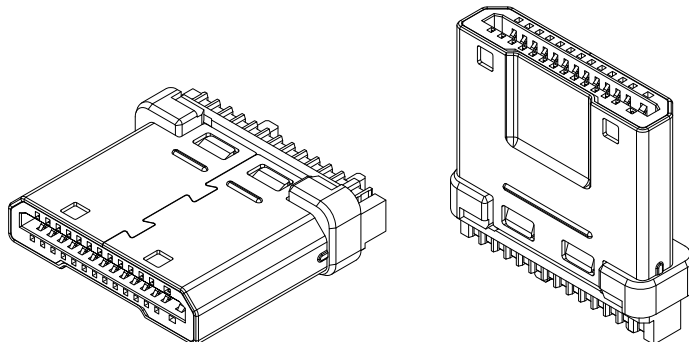
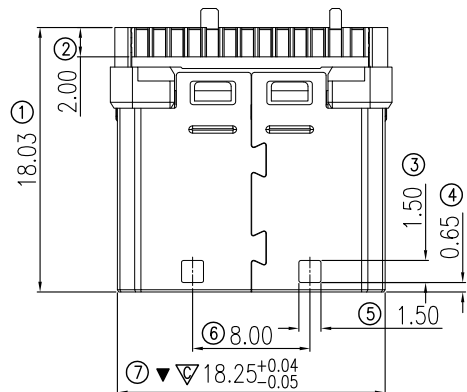

BILL OF MATERIAL:

ITEM	PART NAME	Q'TY	DRAWING NO.	PART NO.	MATERIAL	REMARK
4	SHELL	1	S-ST-HDM-3-00	S-HDM-3-1R**0000	BRASS	NICKEL
3	14PIN INSET MOLDING	1	B-ST-HDM-3-01	B-HDM-3-R**0*01*	THERMOPLASTIC + PHOSPHOR BRONZE	-
2	13PIN INSET MOLDING	1	B-ST-HDM-3-00	B-HDM-3-R**0*00*	THERMOPLASTIC + PHOSPHOR BRONZE	-
1	HOUSING	1	I-ST-HDM-3-00	I-HDM-3-1R**000*	THERMOPLASTIC	-

GENERAL TOLERANCE	ANGLE TOLERANCE	NAME(INTENDED USE):	PALCONN
X. ±0.38 .X ±0.25 .XX ±0.20 .XXX ±0.15	X° ±3.0° .X° ±2.0° .XX° ±1.0°	CUSTOMER DRAWING	
MAJOR(QC CHECKED) ▽= 9 places	SCALE: 1:1	APPROVED:	PALCONN TECHNOLOGY CO.,LTD.
CRITICAL: ▽= 2 places	UNIT: mm	CHECKED:	TITLE: HDMI PLUG, SERIES A, 27 POSITIONS SOLDER TYPE
SHEET 1 OF 1	DESIGN:		SERIES: HDMI SERIES SIZE: A4
			DRAWING NO.: B-ST-HDM-3-02 REV.: B