

| Approved Cable Suppliers |               |             |      |                       |
|--------------------------|---------------|-------------|------|-----------------------|
| Item #                   | Supplier name | Part Number | UL # | Raw cable jacket mark |
| 1                        | PALCONN       | 3B90218001  |      | NO MARK               |
| 2                        | PALCONN       | 3B00118018  |      | NO MARK               |
| 3                        | PALCONN       | 3B00118019  |      | NO MARK               |
| 4                        | PALCONN       | 3B00118020  |      | NO MARK               |
| 5                        | PALCONN       | 3B00118021  |      | NO MARK               |
| 6                        | PALCONN       | 3B00118022  |      | NO MARK               |

| REVISION | INITIALS | REASON                            | DATE    | F | LGH | NEW P1 CONNECTOR & OVERMOLD                  | 11/12/19 |
|----------|----------|-----------------------------------|---------|---|-----|----------------------------------------------|----------|
| A        | LGH      | INITIAL RELEASE                   | 8/20/18 | G | LGH | ITEM #7 WIRE COLOR                           | 12/11/19 |
| B        | LGH      | ADD LABEL, UPDATE WIRE TABLE      | 12/4/18 | H | LGH | CUSTOMER PART NUMBER                         | 12/19/19 |
| C        | LGH      | OVERMOLD STRAIN RELIEF            | 5/14/19 | I | LGH | ITEM#13 POTTING & NOTES                      | 03/23/20 |
| D        | LGH      | WIRE TABLE, NOTES, DETAIL A       | 7/3/19  | J | LGH | P1 CONNECTOR P/N CHANGE/KEYWAY CHANGE B TO A | 04/20/20 |
| E        | LGH      | BDM QTY, LABEL TABLE P1, DETAIL A | 7/23/19 | K | LGH | UPDATE DETAIL A                              | 04/27/20 |
|          |          |                                   |         | L | LGH | UPDATE BDM ITEM#13-15                        | 09/18/20 |

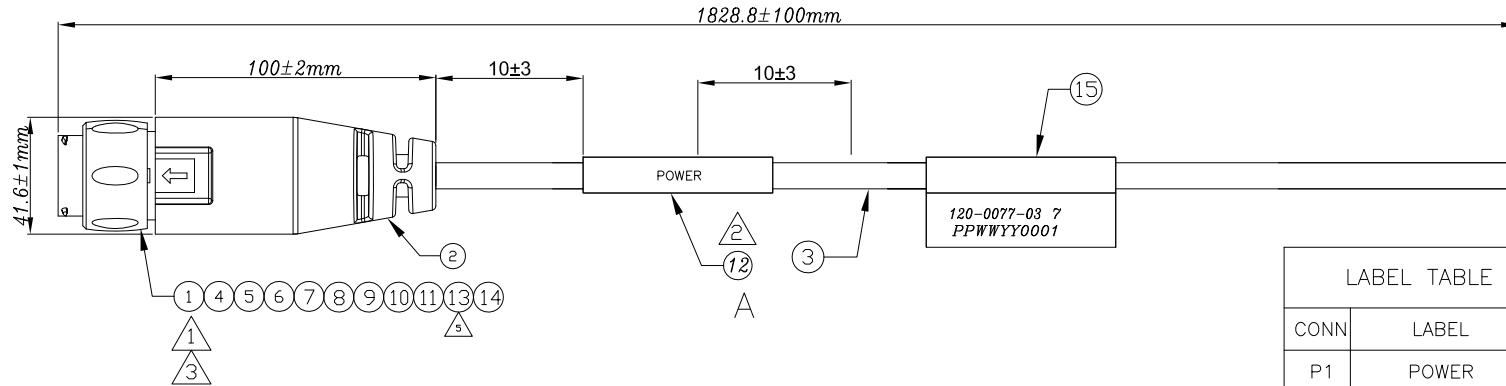
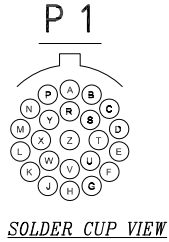

| LABEL TABLE |                                 |
|-------------|---------------------------------|
| CONN        | LABEL                           |
| P1          | POWER                           |
| P1          | P/N 120-0077-03 7<br>PPWWYY0001 |

| WIRE TABLE |        |                     |        |
|------------|--------|---------------------|--------|
| P1         | COLOR  | CUST. DETAIL        | SPEC   |
| PIN X      | RED    | 3V3                 | 18 AWG |
| PIN U      | GREEN  | DGND                | 18 AWG |
| PIN M      | YELLOW | SDA                 | 18 AWG |
| PIN W      | BROWN  | SCL                 | 18 AWG |
| PIN V      | BLUE   | PRESENCE            | 18 AWG |
| -          | -      | -                   | 18 AWG |
| PIN R      | BLACK  | CORE<br>TERMINAL X1 | 18 AWG |
| PIN S      | WHITE  | CORE<br>TERMINAL X2 | 18 AWG |
| PIN Z      | SHIELD | EGND                | 18 AWG |

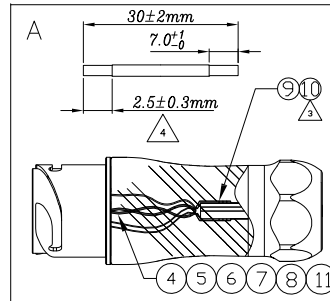

| 15   | LABEL       | 1PC    | L: 75.0MM*W: 30.0M PE MATERIAL WHITE BACKGROUND AND BLACK WORDS.              |
|------|-------------|--------|-------------------------------------------------------------------------------|
| 14   | GLUE        | AR     | LOCTITE P/N: EA E-30CL-EN                                                     |
| 13   | GLUE        | AR     | KAFUTER P/N: K-5096L                                                          |
| 12   | SHRINK TUBE | AR     | TUBING, HEAT SHRINK, PRINTABLE, 19mm BLACK/WHITE PALCONN P/N: CB0010P00012    |
| 11   | SHRINK TUBE | AR     | HEAT-SHRINK TUBING, ID 2.3mm BEFORE SHRINKING, 25FT PALCONN P/N: CB0010P00016 |
| 10   | SHRINK TUBE | AR     | TUBING, SHRINK, .48" x 2.5" LC PALCONN P/N: CB0010P00017                      |
| 9    | PCBA        | 1PC    | PCBA, EEPROM BOARD, CABLE ID                                                  |
| 8    | CABLE       | 1PC    | BLUE 18AWG 1C*18AWG L: 30±2MM PALCONN P/N: 3B00118022                         |
| 7    | CABLE       | 1PC    | BROWN 18AWG 1C*18AWG L: 30±2MM PALCONN P/N: 3B00118019                        |
| 6    | CABLE       | 1PC    | YELLOW 18AWG 1C*18AWG L: 30±2MM PALCONN P/N: 3B00118020                       |
| 5    | CABLE       | 1PC    | GREEN 18AWG 1C*18AWG L: 30±2MM PALCONN P/N: 3B00118021                        |
| 4    | CABLE       | 1PC    | RED 18AWG 1C*18AWG L: 30±2MM PALCONN P/N: 3B00118018                          |
| 3    | CABLE       | 1830mm | 2C*18AWG+F+AL+D+B OD: 5.9±0.2MM XL-PE(MOISTURE CURED)                         |
| 2    | OVERMOLD    | AR     | MATERIAL: TPE BLACK 88A ZHONGXU P/N: MSLTPE00WR021                            |
| 1    | CONNECTOR   | 1PC    | BIX P/N: FS4MAL.A23M00.1500 (RECEPTACLE)                                      |
| ITEM | PART NAME   | Q'TY   | PART NO                                                                       |

**ELECTRICAL PROPERTIES:**

- ASSEMBLY MUST PASS ELECTRICAL TEST "END TO END" THROUGH MATED CONNECTOR, INCLUDE TEST REPORT EACH MFG. LOT.
- WATERPROOF TEST MEETS IP67 1M WATER DEPTH FOR 30 MIN. AND IP68 4.5M WATER DEPTH FOR 48H.

**NOTES:**

- CRIMP P1 CONTACTS USING CONNECTOR MFG RECOMMENDED CRIMP TOOL.
- LABEL AS SHOWN.
- ADD HEAT SHRINK TUBING (ITEM 10) ON TO DRAIN WIRE (ITEM 3), SEE DETAIL A.
- STRIP AND TIN HOOK UP WIRES (ITEM#4-8) TO DIMENSIONS IN DETAIL A. TERMINATE PCB/EEPROM (ITEM#9) TO P1 CONNECTOR (ITEM#1) USING HOOK UP WIRES (ITEM#4-8).
- APPLY GLUE (ITEM#13) TO POT TERMINATION AREA.
- BAG AND TAG WITH PART NUMBER AND REVISION.
- PARTS TO BE CLEAN AND FREE OF DEBRIS, OIL AND OTHER CONTAMINANTS.
- ALL DESIGN AND OR PROCESS CHANGES REQUIRE PRIOR SENTIENT ENERGY APPROVAL. ALL AUTHORIZED DESIGN OR PROCESS CHANGES REQUIRE FIRST ARTICLE INSPECTION APPROVAL BEFORE PRODUCTION IMPLEMENTATION.

| GENERAL TOLERANCE ANGLE TOLERANCE |             | NAME (INTENDED USE) |            |
|-----------------------------------|-------------|---------------------|------------|
| X.                                | ±1.00       | X.°                 | ±3.0°      |
| .X                                | ±0.50       | .X°                 | ±1.0°      |
| .XX                               | ±0.20       | .XX°                | ±0.5°      |
| .XXX                              | ±0.15       |                     |            |
| MAJOR (QC CHECKED)                | SCALE 1 : 1 | APPROVED:           | DATE       |
| ▼ = 8 places                      |             | LCZ                 | 2020/09/18 |
| CRITICAL =                        | UNIT mm     | CHECKED:            | DATE       |
|                                   |             |                     |            |
| SHEET 1 OF 1                      |             | DESIGN:             | DATE       |
|                                   |             | LGH                 | 2020/09/18 |

**PALCONN**

TITLE:  
CABLE ASSY UM3+ KRAKEN CORE

SERIES: SIZE A4

DRAWING NO: A007 SENT R024CN REV L