

REVISION	INITIALS	REASON	DATE
A	LGH	NEW RELEASE	2022/05/07
B	LGH	CHANGED OVERMOLD DESIGN	2022/05/17
C	LGH	CHANGE THE SIZE OF THE INTERNAL FRAME FOR SHEET 7	2022/06/17
D	LGH	MODIFY THE OUTER DIE COLOR ADDED THE EXPOSED DIMENSION OF POGO PIN	2022/09/27
E	LGH	ADD PACKING SPECIFICATION	2022/12/22
F	LGH	CHANGED CABLE JACKET MATERIAL	2023/02/04

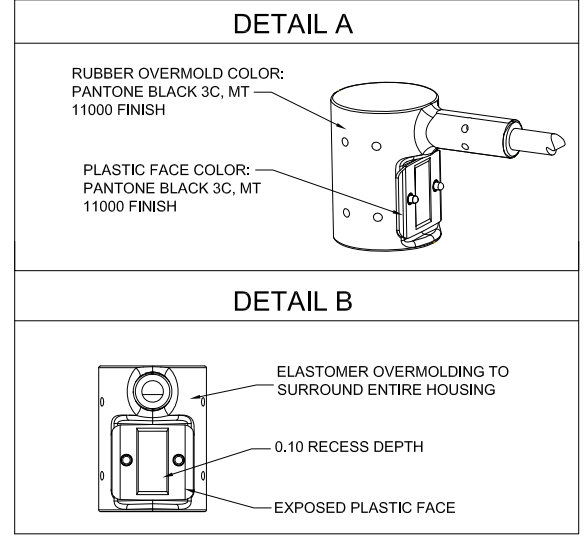
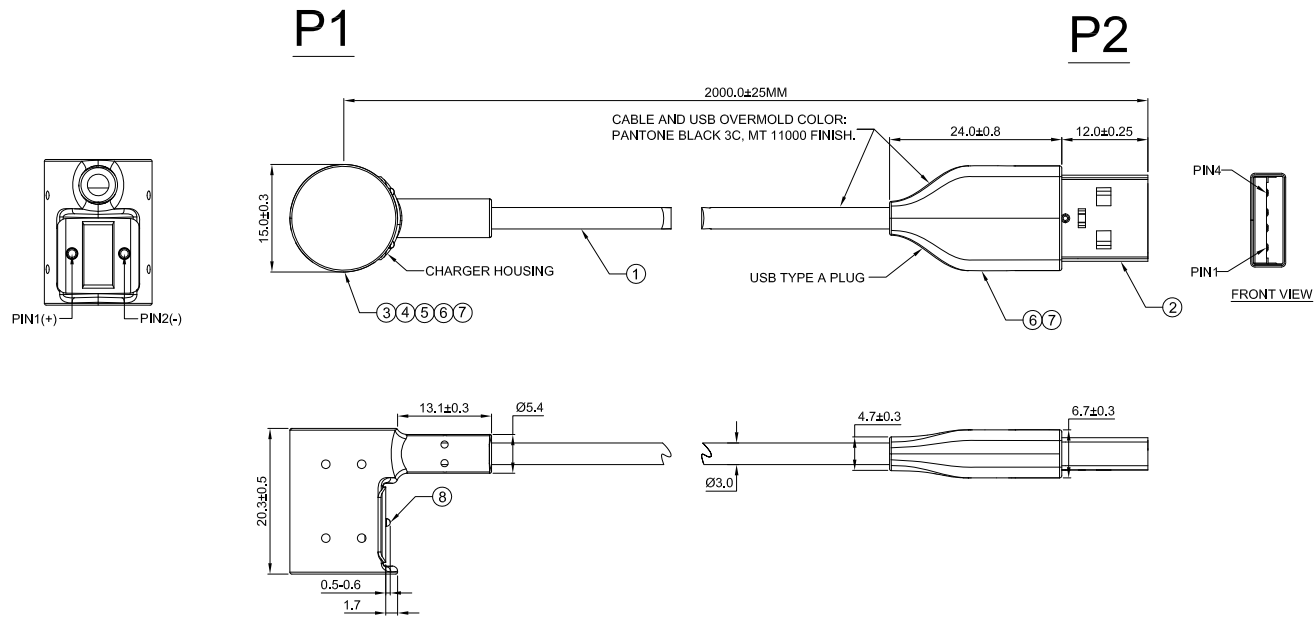

PIN ASSIGNMENT

P1		P2	
Pin	Signal Name	Color	Pin
PIN1	VBUS	RED	PIN1
PIN2	GND	WHITE	PIN4

ELECTRICAL PROPERTIES:
1. 100% OPEN, SHORT & MIS-WIRE TEST

8	POGO PIN	2PCS	MILL-MAX P/N: 0906-8-15-20-76-14-11-0	
7	OUTER MOLDING	AR	MATERIAL: TPE (PANTONE BLACK 3C 80A)	
6	INTERNAL MODEL	AR	MATERIAL: PP	
5	PLASTIC SHELL	AR	EXPOSED PLASTIC FACE	
4	NEODYMIUM MAGNET	4PCS	NEODYMIUM MAGNET: Ø3.17*L6.35 N52 MATERIAL: NDFEB MAGNET NICKEL PLATED 1U"	
3	PCBA	1PC	TBD	
2	CONNECTOR	1PC	NO MARKING 22AWG*2C+TALCUM POWDER BLACK COLD RESISTANT BRASS, INSULATION PBT/LCP BLACK, SHELL NICKEL PLATED 1U".	
1	CABLE	2M	24AWG*2C+TALCUM POWDER TPE (PANTONE BLACK 3C 80A) OD: 3.00±0.15mm XINTAI#TPE002JX80 TPE 80A FLAME RETARDANT	
ITEM	PART NAME	QTY	PART NO:	DESCRIPTION

GENERAL TOLERANCE	ANGLE TOLERANCE	NAME (INTENDED USE)			
X. ±1.00 .X ±0.50 .XX ±0.20 .XXX ±0.15		CUSTOMER P/N:			
MAJOR (QC CHECKED) ▼ = 1 places		APPROVED: LGZ	DATE 2023/02/04	TITLE: OUTLINE DRAWING, DONGLE CHARGER ASY, ATHENA	
	UNIT mm	CHECKED: LJJ	DATE 2023/02/04	SERIES:	SIZE: A4
SHEET 1 OF 2		DESIGN: LGH	DATE 2023/02/04	DRAWING NO: MED-MD-001-088	REV F

RoHS Compliant