

REVISION	INITIALS	REASON	DATE
A	LGH	NEW RELEASE	2022/09/19
B	LGH	UPDATE DRAWING	2023/03/27
C	LGH	ADDITIONAL PACKING SPECIFICATION	2023/04/25
D	LGH	CHANGE THE TOTAL CABLE LENGTH	2023/07/05
E	LGH	REMOVE THE FEMALE BUCKLE SHELL	2023/07/18
F	LGH	ADDED THE BLACK PLASTICS PART, MODIFY PACKING	2023/10/21
G	LGH	CHANGE THE TOTAL TOLERANCE SIZE FROM 3.0MM TO 1.5MM.	2023/12/05

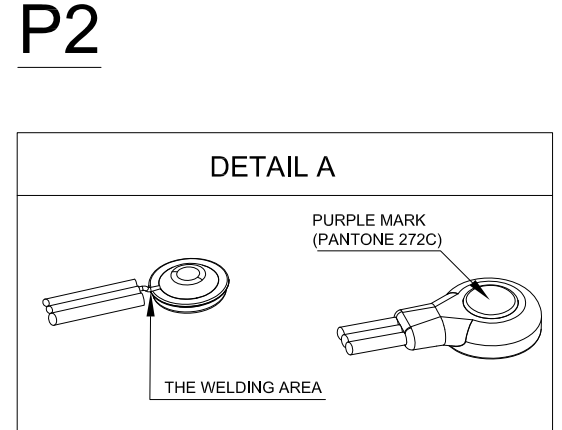

PIN ASSIGNMENT

P1	COLOR	P2
PIN1	DRAIN	N/A
PIN2	WHITE	PIN1
PIN3	DRAIN	N/A

ELECTRICAL PROPERTIES:
1. 100% OPEN, SHORT & MIS-WIRE TEST

NOTES:
1. SOLDER WITH Sn96.5/Ag03/Cu.5 SOLDER (LEAD FREE).

9	MODULE	1PC		MATERIAL: PA-757 ABS WHITE
8	MODULE	1PC		MATERIAL: PA-757 ABS BLACK
7	OUTER MOLDING	AR		MATERIAL: TPU (PANTONE 272C)
6	METAL BUTTON	1PC		4.0 MEDICAL BUCKLE, MATERIAL: COPPER PLATED BRIGHT NICKEL
5	MODULE	1PC		MATERIAL: PA-757 ABS WHITE
4	OUTER MOLDING	AR		MATERIAL: TPU (PANTONE 272C)
3	SEALING RING	1PC		SILICA GEL SIZE : C188MM*Ø0.8MM
2	ENCLOSURE FRONT SHELL	1PC		MATERIAL: PA-757 ABS ALPINE WHITE (PANTONE 11-0602TCX)
1	CABLE	88.0MM		{(1C*28#*S)*1C+(PVC STRIPE*S)*2C}*3F MEDICAL LEVEL TPU PANTONE 272C 2.00±0.15MM*6.00±0.15MM
ITEM	PART NAME	Q'TY	PART NO:	DESCRIPTION
GENERAL TOLERANCE		ANGLE TOLERANCE		NAME(INTENDED USE)
X. ±1.00				CUSTOMER P/N:
.X ±0.50				
.XX ±0.20				
.XXX ±0.15				
MAJOR(QC CHECKED)				
▼ = 0 places				DATE: 2023/12/05
		UNIT mm		CHECKED: LJJ
				DATE: 2023/12/05
				DESIGN: LGH
				DATE: 2023/12/05
SHEET 1 OF 2				TITLE: RSW-PATCH_FRONT COVER_3.0.0 WITH PURPLE CABLE,
				SERIES:
				SIZE: A4
				DRAWING NO: MED-MD-001-095
				REV G

RoHS Compliant